

RPX Couplings

RPX Coupling selection procedure Based on Power and Speed

- 1] **Service Factor**
From Table 1 on page 260, select the service factor that is appropriate for the application
- 2] **Design Power**
Multiply the absorbed power, kW, of the driven machine by the service factor, from step 1) to obtain the design power.
If the absorbed power is not known, use the prime mover power.
- 3] **RPX coupling size selection**
Refer to Table 2 on page 261 and select either the standard 92 shore spider or the higher torque 98 shore spider.
Read down the left hand vertical column to the required speed. (Interpolate if the exact speed is not listed).
Read horizontally across on the speed line until a power equal to or in excess of the design power, from step 2), is reached.
Read vertically to the top of the column to obtain the correct size of RPX coupling.
- 4] **Bore dimensions**
From the dimension Tables on page 263, check that the selected coupling will fit the shafts.

Based on IEC Electric Motors, see page 262

- 1] Note the frame size of the motor, power, speed (or number of poles)
- 2] Read across to the column headed by the motor speed (or number of poles)
- 3] The next column to the motor power gives the size of RPX coupling required

RPX Coupling selection example

Select a Challenge RPX coupling to couple an 11.0 kW, 1450 rev/min motor to a hammer mill which absorbs 9.6 kW running for 12 hours per day with no more than 30 stops/starts per hour. A good shock absorbing spider is required for this heavy duty application.

The ambient temperature is + 38°C. The motor shaft is 42mm diameter and the kiln shaft 38mm.

- 1] **Service factor**
From Table 1 on page 260, the service factor for this application is: $1.75 \times 1.2 \times 1.0 = 2.1$
- 2] **Design power**
The design power is $9.6 \times 2.1 = 20.2$ kW

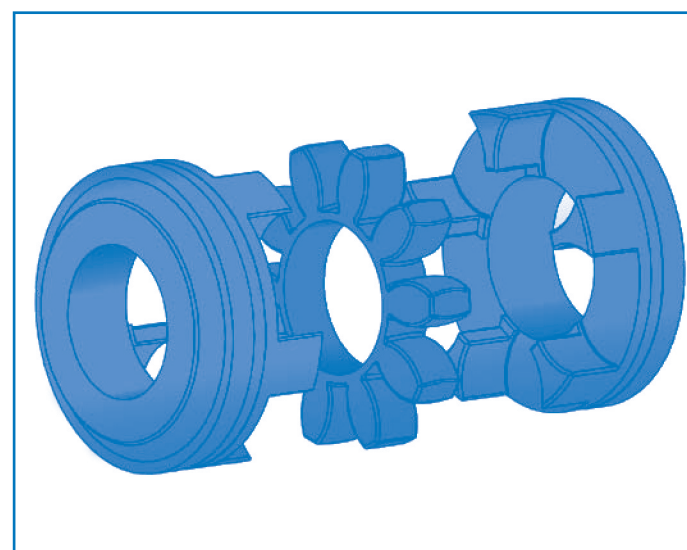

- 3] **RPX coupling size selection**
Because of its shock absorbing characteristics, the 92 shore spider is chosen: Refer to Table 2 on page 261

By reading down and interpolating for the required speed of 1450 rev/min, it is seen that an RPX size 38 will transmit 28.9 kW which is in excess of the 20.2 kW required from step 2)
- 4] **Bore dimensions**
From the dimension Tables on page 263, the flanges on an RPX 38 take an 1108 taper bush with a maximum bore of 28mm. Therefore, pilot bore flanges will be required as follows: Flange Type 1 bored 38mm and flange Type 1a bored 42mm

If taper bore flanges are required then a RPX size 42 will have to be used. The RPX size 42 utilises a 1610 taper bush with a maximum bore of 42mm.

RPX Coupling Selection

Table 1, Service Factors

Special cases For applications where shock, vibration and torque fluctuations occur – consult Challenge	Type of prime mover		
	Electric motors and other smooth running devices	Internal combustion engines with 4 or more cylinders	Internal combustion engines with less than 4 cylinders
Type of driven machine			
Uniform load Light duty agitators, belt conveyors for sand etc., fans up to 7.5 kW, centrifugal compressors and pumps,	1.0	1.25	1.50
Moderate load Variable density agitators, belt conveyors (non-uniform loads), fans over 7.5 kW, other rotary compressors and pumps, machine tools, printing machinery, laundry machinery, rotary screens, rotary woodworking machinery	1.25	1.50	2.00
Heavy load Reciprocating compressors and pumps, positive displacement blowers, heavy duty conveyors such as screw, bucket etc., hammer mills, pulverisers, presses, shears, punches, rubber machinery, crushers, metal mills	1.75	2.00	2.50

The above Service Factors are based on 24 hours/day duty

Additional service factor multiplier for temperature : -30°C to +30° = 1.00, +40°C = 1.2, +60°C = 1.4, +80°C = 1.8

Additional frequent start multiplier : up to 100 starts/hour = 1.0 100-200 = 1.2 200-400= 1.4 400-800=1.6

Challenge elements are manufactured from polyurethane with an operating temperature span between -40°C to +100°C.

They can also accommodate transient temperatures up to +120°C

RPX Coupling Selection

Table 2, Power Ratings (kW) for 92 shore elements (Yellow)

Rotational speed in rev/min	19	24	28	38	42	48	55	65	75	90
100	0.10	0.37	1.00	1.99	2.78	3.25	4.29	6.55	13.4	25.1
500	0.52	1.83	4.98	9.95	13.9	16.2	21.5	32.7	67.0	126
700	0.73	2.56	6.97	13.9	19.4	22.7	30.1	45.8	93.8	176
720	0.75	2.64	7.16	14.3	20.0	23.4	30.9	47.1	96.5	181
800	0.84	2.93	7.96	15.9	22.2	26.0	34.3	52.4	107	201
900	0.94	3.29	8.96	17.9	25.0	29.2	38.6	58.9	121	226
960	1.01	3.51	9.55	19.1	26.6	31.2	41.2	62.8	129	241
1000	1.05	3.66	9.95	19.9	27.8	32.5	42.9	65.5	134	251
1200	1.26	4.39	11.9	23.9	33.3	39.0	51.5	78.5	161	302
1400	1.47	5.12	13.9	27.9	38.9	45.4	60.1	91.6	188	352
1440	1.51	5.27	14.3	28.7	40.0	46.7	61.8	94.2	193	362
1500	1.57	5.49	14.9	29.9	41.6	48.7	64.4	98.2	201	377
1800	1.88	6.59	17.9	35.8	50.0	58.4	77.3	118	241	452
2000	2.09	7.32	19.9	39.8	55.5	64.9	85.9	131	268	503
2500	2.62	9.15	24.9	49.8	69.4	81.2	107	164	335	628
2880	3.02	10.5	28.7	57.3	79.9	93.5	124	188	386	724
3000	3.14	11.0	29.9	59.7	83.3	97.4	129	196	402	754
3500	3.66	12.8	34.8	69.7	97.1	114	150	229	469	880
4000	4.19	14.6	39.8	79.6	111	130	172	262	536	-
4500	4.71	16.5	44.8	89.6	125	146	193	295	603	-
5000	5.24	18.3	49.8	99.5	139	162	215	327	-	-

All power ratings are constant torque
Interpolate for speeds not listed

92 shore (yellow) are the standard elements and 98 shore (red) elements can be used for higher torques.

Table 2, Power Ratings (kW) for 98 shore elements (Red)

Rotational speed in rev/min	19	24	28	38	42	48	55	65	75	90
100	0.18	0.63	1.68	3.40	4.71	5.50	7.17	9.84	20.1	37.7
500	0.89	3.14	8.38	17.0	23.6	27.5	35.9	49.2	101	189
700	1.25	4.40	11.7	23.8	33.0	38.5	50.2	68.9	141	264
720	1.28	4.52	12.1	24.5	33.9	39.6	51.6	70.9	145	271
800	1.42	5.02	13.4	27.2	37.7	44.0	57.4	78.7	161	302
900	1.60	5.65	15.1	30.6	42.4	49.5	64.6	88.6	181	339
960	1.71	6.03	16.1	32.7	45.2	52.8	68.9	94.5	193	362
1000	1.78	6.28	16.8	34.0	47.1	55.0	71.7	98.4	201	377
1200	2.14	7.54	20.1	40.8	56.5	66.0	86.1	118	241	452
1400	2.49	8.79	23.5	47.6	66.0	77.0	100	138	281	528
1440	2.56	9.04	24.1	49.0	67.9	79.2	103	142	290	543
1500	2.67	9.42	25.1	51.0	70.7	82.5	108	148	302	566
1800	3.20	11.3	30.2	61.3	84.8	98.9	129	177	362	679
2000	3.56	12.6	33.5	68.1	94.2	110	143	197	402	754
2500	4.45	15.7	41.9	85.1	118	137	179	246	503	943
2880	5.13	18.1	48.2	98.0	136	158	207	283	579	1086
3000	5.34	18.8	50.3	102	141	165	215	295	603	1131
3500	6.23	22.0	58.6	119	165	192	251	345	704	1320
4000	7.12	25.1	67.0	136	188	220	287	394	804	-
4500	8.01	28.3	75.4	153	212	247	323	443	905	-
5000	8.90	31.4	83.8	170	236	275	359	492	-	-

All power ratings are constant torque
Interpolate for speeds not listed

92 shore (yellow) are the standard elements and 98 shore (red) elements can be used for higher torques.

RPX Coupling Selection

IEC Motor Selection Table (50Hz)

Frame size shaft diameter and length		Motor power (kW) 2-pole 3000 rev/min	RPX size *	Motor power (kW) 4-pole 1500 rev/min	RPX size *	Motor power (kW) 6-pole 1000 rev/min	RPX size *	Motor power (kW) 8-pole 750 rev/min	RPX size *	
	2 pole	4, 6, 8 pole								
80	19 x 40		0.75	19 / 24	0.55	19 / 24	0.37	19 / 24	0.18	19 / 24
			1.1	19 / 24	0.75	19 / 24	0.55	19 / 24	0.25	19 / 24
90S	24 x 50		1.5	19 / 24	1.1	19 / 24	0.75	19 / 24	0.37	19 / 24
90L			2.2	19 / 24	1.5	19 / 24	1.1	19 / 24	0.55	19 / 24
100L	28 x 60		3.0	24 / 28	2.2	24 / 28	1.5	24 / 28	0.75	24 / 28
					3.0	24 / 28			1.1	24 / 28
112M			4.0	24 / 28	4.0	24 / 28	2.2	24 / 28	1.5	24 / 28
132S	38 x 80		5.5	28 / 42	5.5	28 / 42	3.0	28 / 42	2.2	28 / 42
			7.5	28 / 42						
132M					7.5	28 / 42	4.0	28 / 42	3.0	28 / 42
							5.5	28 / 42		
160M	42 x 110		11	38 / 42	11	38 / 42	7.5	38 / 42	4.0	38 / 42
			15	38 / 42					5.5	38 / 42
160L			18.5	38 / 42	15	38 / 42	11	38 / 42	7.5	38 / 42
180M	48 x 110		22	38 / 42	18.5	42 / 55				
180L					22	42 / 55	15	42 / 55	11	42 / 55
200L	55 x 110		30	42 / 65	30	42 / 65	18.5	42 / 65	15	42 / 65
			37	42 / 65			22	42 / 65		
225S	55 x 110	60 x 140			37	48 / 65			18.5	48 / 65
225M			45	42 / 65	45	55 / 65	30	55 / 65	22	55 / 65
250M	60 x 140	65 x 140	55	48 / 65	55	55 / 65	37	65 / 65	30	65 / 65
280S		75 x 140	75	48 / 65	75	65 / 75	45	65 / 75	37	65 / 75
280M			90	48 / 65	90	75 / 75	55	75 / 75	45	75 / 75
315S		80 x 170	110	65 / 65	110	75 / 90	75	75 / 90	55	75 / 90
315M	65 x 140		132	65 / 65	132	75 / 90	90	75 / 90	75	90 / 90
			160	65 / 65	160	90 / 90	110	90 / 90	90	90 / 90
315L			200	75 / 75	200	90 / 90	132	90 / 90	110	90 / 90
			160	90 / 90			132	90 / 90	132	90 / 90
315		85 x 170	250	75 / 75	250	90 / 90	200	90 / 90		

The above selection procedure is based on the following parameters:-

- Service factor of 2.0
- 30° C maximum temperature
- 92 Shore insert
- 100 starts per hour maximum

If the parameters differ from the above, selection should be based on power and speed

* Pilot bore flanges are in **bold normal** type face

* Taper bore flanges are in *light italic* type face

RPX Coupling Selection

RPX Coupling Data - Pilot bored

TYPE	Max Speed rev/min	Rated Torque		D	D ₁	d-min	d-max	S	L ₁	L ₂	L	Material	Weight kg/hub
		92 shore Nm	98 shore Nm										
19 1	19000	10	17	40	32	6	19	1.0	39.0	25	65	Al	0.19
1a				40	-	19	24	1.0	39.0	25	65	Al	-
24 1	14000	35	60	56	40	9	24	1.0	46.0	30	77	Al	0.38
1a				56	-	22	28	1.0	46.0	30	77	Al	-
28 1	11800	95	160	65	48	10	28	1.5	52.5	35	89	Al	0.62
1a				65	-	28	38	1.5	52.5	35	89	Al	-
38 1	9500	190	325	80	66	12	38	1.0	66.0	45	112	CI	1.36
1a				80	-	38	45	1.0	66.0	45	112	CI	-
42 1	8000	265	450	95	75	14	42	1.0	73.0	50	124	CI	2.03
1a				95	-	42	55	1.0	73.0	50	124	CI	-
48 1	7100	310	525	105	85	15	48	1.5	80.5	56	138	CI	2.85
1a				105	-	48	60	1.5	80.5	56	138	CI	-
55 1	6300	410	685	120	98	20	55	2.0	91.0	65	158	CI	4.32
1a				120	-	55	70	2.0	91.0	65	158	CI	-
65 1	5600	625	940	135	115	20	65	1.5	105.5	75	182	CI	6.66
1a				135	-	65	80	1.5	105.5	75	182	CI	-
75 1	4750	1280	1920	160	135	30	75	1.0	120.0	85	206	CI	10.48
1a				160	-	75	95	1.0	120.0	85	206	CI	-
90 1	3750	2400	3600	200	160	40	90	1.5	139.5	100	241	CI	17.89
1a				200	180	90	115	1.5	139.5	100	241	CI	-

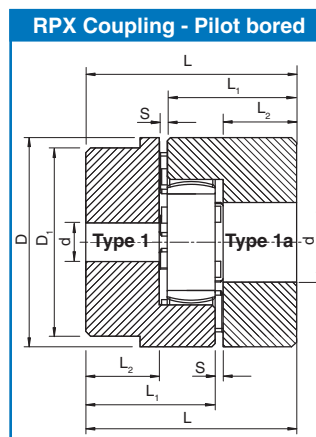

RPX Coupling Data - Taper bored

TYPE	Max Speed rev/min	Rated Torque		Bush Size	Max Bore	D	D ₁	S	L ₁	L ₂	L	Material	Weight kg/hub
		92 shore Nm	98 shore Nm										
24 F	14000	35	60	1008	25	56	-	1.0	39.0	23	63	CI	0.31
H				1008	25	56	-	1.0	39.0	23	63	CI	0.31
28 F	11800	95	160	1108	28	65	-	1.5	40.5	23	65	CI	0.46
H				1108	28	65	-	1.5	40.5	23	65	CI	0.46
38 F	9500	190	325	1108	28	80	78	1.0	44.0	23	68	CI	0.79
H				1108	28	80	78	1.0	44.0	23	68	CI	0.79
42 F	8000	265	450	1610	42	95	94	1.0	49.0	26	76	CI	1.10
H				1610	42	95	94	1.0	49.0	26	76	CI	1.10
48 F	7100	310	525	1615	42	105	104	1.5	63.5	39	104	CI	2.07
H				1615	42	105	104	1.5	63.5	39	104	CI	2.07
55 F	6300	410	685	2012	50	120	118	2.0	59.0	33	94	CI	2.22
H				2012	50	120	118	2.0	59.0	33	94	CI	2.22
65 F	5600	625	940	2012	50	135	133	1.5	63.5	33	98	CI	3.14
H				2517	65	135	133	1.5	75.5	45	122	CI	4.03
75 F	4750	1280	1920	2517	65	160	135	1.0	81.0	46	128	CI	4.69
H				3020	75	160	135	1.0	87.0	52	140	CI	4.99
90 F	3750	2400	3600	3020	75	200	160	1.5	91.5	52	145	CI	7.74
H				3525	100	200	160	1.5	103.5	64	169	CI	8.74

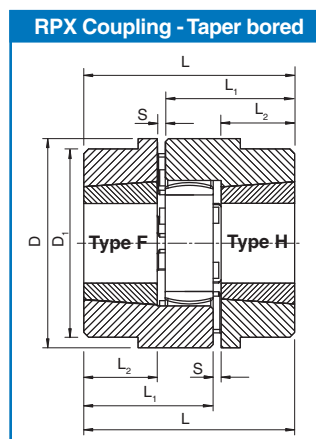

RPX Elements are manufactured from polyurethane and are available in Shore 92 (yellow) and Shore 98 (red) hardness

Material: Al = Aluminium CI = GG25 Cast Iron